

**Specification
for
Lithium-ion Rechargeable Cell**

Cell Type :LPT36130170-50PF

Approved	Checked	Prepared
HX Shi	ZH Hu	YY Wang

Contents

1. Preface
2. Description
3. Cell Size
4. Construction
5. Specification
6. Test Conditions
 - 6.1 Standard Test Conditions
 - 6.2 Standard Charge Method
7. Electrical Characteristics
8. Environmental Characteristics
9. Safety Test
10. Shipment
11. Warranty
12. Precautions and Safety Instructions
 - 12.1 Standard cell Precautions
 - 12.2 Cell Operation Instructions
 - 12.2.1 Charging
 - 12.2.2 Discharging
 - 12.2.3 Storage Recommendation

1. Preface

This Product Specification describes the technique requirements, test procedures and precaution notes of Lithium-ion Rechargeable cell.

2. Description

2.1 Product: Lithium-ion Rechargeable cell

2.2 Model (Type): LPT36130170-50PF

2.3 Designation:

36 130 170 - 50 P F

① ② ③ ④ ⑤ ⑥

①: Indicates the Thickness of cell T

T 36=36mm, ± 1 mm

②: Indicates the overall Width of cell W

W 130=130mm, ± 1 mm

③: Typical battery height H

H 170=170mm, ± 2 mm

④: 50 Indicates the capacity of cell

50Ah

⑤: Indicates the performance of cell

The letter "P" defines high power cell

"P"

⑥: The letter "F" defines LiFePO₄ series cathode

3. Cell Size

For details, please refer to Figure A. Remark: contain package (PVC heat-shrinkable).

4. construction

A cell is made of cathode, anode, separator, aluminum can and caps.



图 A

LI-ION POWER TECHNOLOGY

5.Specification

Item		Specification	Remark 备注
5.0 Typical Capacity		50.5Ah	temperature:23±2°C
5.1 Minimum Capacity		50Ah	0.3C discharge capacity
5.2 Internal Impedance		≤0.8mΩ	By AC 1 KHZ
5.3 Nominal Voltage		3.2V	
5.4 Cell Weigh		≤1.5kg	contain package
5.5 End-of-charge Voltage		3.65V	At CC mode
5.6 End-of-discharge Voltage		2.2V	
5.7Charge Method		0.3C CC/CV	
5.8 Max Pulse Discharge current		500A	Pulse Current width: 10C Under 10 Seconds
5.9 Max Continuous Discharge current		150A	Continuous Discharge current: Under 3C
5.10 Max Pulse charge current		100A	Pulse Current width:2c Under 10Seconds
5.11 Standard charge current		15A	0.3C
5.12Cycle Life		≥2500 cycles	15A Charge&Discharge (100% DOD)Rest Capacity over80%
5.13 Operating Temperature Range	Charging Temperature	0~50°C	Recommended temperature range for long term storage is 0~+50°C
	Discharging Temperature	-20~50°C	Recommended temperature range for long term storage is -20~+50°C
	Storage Temperature	-10~45°C	Recommended temperature range for long term storage is -10 ~ +45°C
5.14 Shelf Life		3year	Typical value from ship state
5.15 Appearance		Without break, scratch, distortion, contamination, leakage and so on	

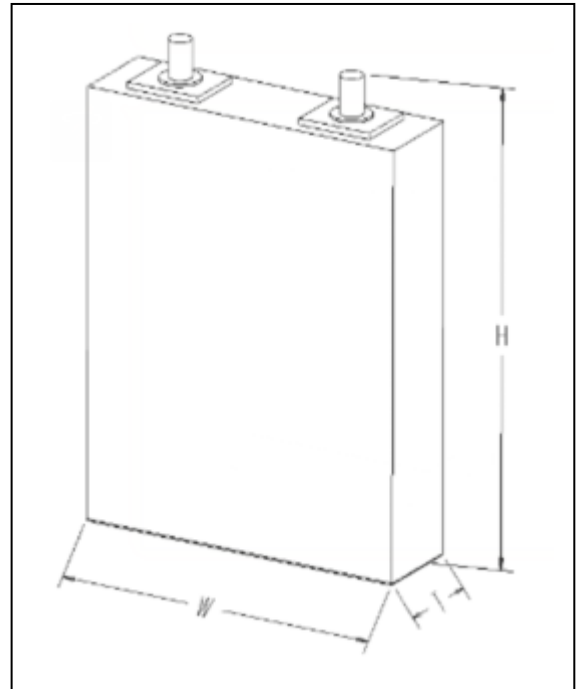
6.Test Conditions

6.1 Unless otherwise specified, all tests stated in this Product Specification are conducted at temperature 23°C±2°C and Humidity<75%RH.

6.2 Standard Charge Method

LI-ION POWER TECHNOLOGY

The "Standard Charge" means in an ambient temperature of $23^{\circ}\text{C}\pm 2^{\circ}\text{C}$, charging the Cell at a constant current of 0.3C until the voltage is 3.65V, then charged at a constant voltage of 3.65V Until current is less than 0.05C.

7. Electrical characteristics

Test Item	Test Method	Criteria
7.1 High Temperature Performance	A cell is charged in accordance with 6.2, and stored in an ambient temperature of $50^{\circ}\text{C}\pm 2^{\circ}\text{C}$ for 4hrs, then discharged to cut-off voltage at a constant current of 0.3C. After that, fetch out the cell and place it in the ambient temperature of $23^{\circ}\text{C}\pm 2^{\circ}\text{C}$ for 4hrs, then check its appearance.	1.Capacity retention: $\geq 90\%$; 2. No distortion, no rupture.
7.2 Low Temperature Performance	A cell is charged in accordance with 6.2, and stored in an ambient temperature of $-20^{\circ}\text{C}\pm 2^{\circ}\text{C}$ for 20hrs, then discharged to cut-off voltage :2.0V at a constant current of 0.3C . After that, fetch out the cell and place it in the ambient temperature of $23^{\circ}\text{C}\pm 2^{\circ}\text{C}$ for 4hrs, then check its appearance.	1.Discharge Capacity Percentage Ratio : $\geq 65\%$; 2.No distortion , no rupture
7.3 Room Temperature Powerful Discharge Performance	A cell is charged in accordance with 6.2, and stored in an ambient temperature of $23^{\circ}\text{C}\pm 2^{\circ}\text{C}$ for 20hrs, then discharged to cut-off voltage :2.2V at a constant current of 3C . After that, fetch out the cell and place it in the ambient temperature of $23^{\circ}\text{C}\pm 2^{\circ}\text{C}$ for 4hrs, then check its appearance.	1. Discharge Capacity Percentage Ratio : $\geq 95\%$; 2.No distortion, no rupture
7.4 Cycle Life ($23^{\circ}\text{C}\pm 2^{\circ}\text{C}$)	A cell is charged to end-of-charge voltage at a current of 0.3C, and then charged at a constant voltage of 3.65V until the charge current is less than 0.05C, after that stored for 30min; Discharged to cut-off voltage at a constant current of 0.3C, after that, stored 30min prior to next charge- discharge cycle. The cell shall be continuously charged and discharged for 2500 times.	capacity retention: $\geq 80\%$

8. Environmental Characteristics

Test Item	Test Method	Criteria 检验标准
8.1 Constant Temperature and Humidity	A cell is charged in accordance with 6.2, and stored in an ambient temperature of $40\pm 2^{\circ}\text{C}$ (90 ~ 95%RH) for 48hrs, then placed in room temperature for 2hrs. After that, check its appearance prior to being discharged to cut-off voltage at a constant current of 0.3C.	1.No distortion ,no, rust no fume, no explosion; 2.Capacity retention: $\geq 80\%$
8.2 Temperature Test	A cell is charged in accordance with 6.2, then heated the cell to be in a oven. then the temperature of the oven is to be raised to the temperature of $70^{\circ}\text{C}\pm 3^{\circ}\text{C}$ and remain for 4h at that temperature, then the temperature of the oven is to be dropped to the temperature of $20^{\circ}\text{C}\pm 3^{\circ}\text{C}$ and	No leakage, no fire, no explosion, no vent

LI-ION POWER TECHNOLOGY

	remain for 4h at that temperature, then the temperature of the oven is to be dropped to the temperature of $-40^{\circ}\text{C}\pm 3^{\circ}\text{C}$ and remain for 4hrs at that temperature, repeat this for another 9 cycles, after that put the cell in room temperature for at least 24hrs, then check cell's appearance.	
8.3 Low-pressure Test	A cell is charged in accordance with 6.2, then stored it for 6hrs at a vacuum of -0.90mPa , after that put the cell in room temperature for 6hrs, then check cell's appearance.	No leakage, no fire, no explosion, no vent
8.4 Vibration Test	A cell is charged in accordance with 6.2, then installed onto the vibration desk with clamps. Equipment parameters of frequency and amplitude are as follows (the frequency is to be varied at the rate of 1oct/min between 10 and 55 Hz, and repeat vibration for 30min. The cell is to be tested in three mutually perpendicular directions): frequency: 10Hz~30Hz amplitude: 0.38mm frequency: 30Hz~55Hz amplitude: 0.19mm	1.No scratch, no fire, no explosion, no vent; 2.The voltage is not less than 3.35V.

9. Safety Test

All below tests are carried out on the equipment with forced ventilation and explosion-proof device. Before test, all cells are charged in accordance with 6.2, and stored 24hrs prior to testing.

Test Item	Test Method	Criteria
9.1 55°C Short-circuit Test	A oven is to be raised to the temperature of 55°C and remain for 10min at that temperature. A cell is to be placed into the oven and remain for 30min~40min. Then the Cell is to be short-circuited by connecting the positive and negative terminals of the cell with copper wire having a maximum resistance load of $50\text{m}\Omega$. Monitor its temperature while testing, the cell is to be discharged until the cell case temperature has returned to be 10°C less than peak temperature.	1.No fire, no explosion 2.Max.temp.< 150°C
9.2 Overcharge Test (3C/5V)	A cell is discharged to cut-off voltage at CC of 0.3C. then it is to be subjected to CC/CV power by connecting its positive & negative terminal, then set the current as 3C, the voltage as 5V, after that, Charge the cell up to 5V at CC of 3C, until that last 7h at the voltage of 5V or the voltage is no more increased. 先将电池以 0.3C	No fire, no explosion
9.3 Forced-Discharge Test	A cell is discharged to cut-off voltage 0V at a constant current of 1C.	No fire, no explosion,

LI-ION POWER TECHNOLOGY

9.4 Crush Test	A cell is to be placed on the crush flat, the axis is parallel to the crush flat ,it is to be crushed between two flat surfaces. Crushing force is approximately 13 KN and hold for 1 min.	No fire, no explosion
9.5 Impact Test	A cell is to be placed on the impact flat.A $\Phi 15.8$ mm bar is to be placed on the center of the cell.A 9.1kg weight is to be dropped from a height of 610mm onto the cell, the distortion is allowed.	No fire, no explosion
9.6 Heating Test (130°C)	A cell is to be heated in a circulating air oven. The temperature of the oven is to be raised at a rate of $5^{\circ}\text{C}\pm 2^{\circ}\text{C}$ per minute to a temperature of $130^{\circ}\text{C}\pm 2^{\circ}\text{C}$ and remain for 30min at that temperature before the test is discontinued.	No fire, no explosion

10.Shipment

The Cell shall be shipped in voltage range of 3.2 ~ 3.4V or in accordance with customers' requirement.The remaining capacity before charging shall be changed depending on the storage time and conditions.

11.Warranty

The Warranty period of cell is made according to business contract, However, even though the problem occurs within this period, LPT won't replace a new cell for free as long as the problem is not due to the failure of LPT manufacturing process or is due to customer's abuse or misuse.

LPT will not be responsible for trouble occurred by handling outside of the precautions in instructions.

LPT will not be responsible for trouble occurred by matching electric circuit, cell pack and charger.

LPT will be exempt from warrant any defect cells during assembling after acceptance.

12.Precautions and Safety Instructions

Lithium-ion rechargeable batteries subject to abusive conditions can cause damage to the cell and/or personal injury. Please read and observe the standard cell precautions below before using utilization.

Note 1. The customer is required to contact LPT in advance, if and when the customer needs other applications or operating conditions than those described in this document.

Note 2. LPT will take no responsibility for any accident when the cell is used under other conditions than those described in this Document.

12.1 Standard cell Precautions

- a. Do not expose the cell to extreme heat or flame.
- b. Do not short circuit, over-charge or over-discharge the cell.
- c. Do not subject the cell to strong mechanical shocks.
- d. Do not immerse the cell in water or sea water, or get it wet..
- f. Do not disassemble or modify the cell.
- g. Do not handle or store with metallic like necklaces, coins or hairpins, etc.
- h. Do not use the cell with conspicuous damage or deformation.
- i. Do not connect cell to the plug socket or car-cigarette-plug.
- j. Do not make the direct soldering onto a cell.
- k. Do not touch a leaked cell directly.
- l. Do not use for other equipment.
- m. Do not use Lithium-ion cell in mixture.

- n. Do not use or leave the cell under the blazing sun (or in heated car by sunshine).
- o. Keep cell away from children.
- p. Do not drive a nail into the cell, strike it by hammer or tread it.
- q. Do not give cell impact or fling it.

12.2 Cell Operation Instructions

12.2.1 Charging

- a. Charge the cell in a temperature range of 0°C to + 50°C.
- b. Charge the cell at a constant current of 0.3C until 3.65V, and then at a constant voltage of 3.65V until 0.05C.

Charge rates greater than 1C are NOT recommended. (C : Rated Capacity of cell)

- c. Use a constant current, constant voltage (CC/CV) lithium-ion (Li+) cell charge controller.
- d. Do not continue to charge cell over specified time.

12.2.2 Discharging

- a. Recommended cut-off voltage to 2.2V. Recommended max continuous discharge current is 3C.
- b. For maximum performance, discharge the cell in a temperature range of -20°C to +50°C.

12.2.3 Storage Recommendations

In case of long period storage (more than 3 months), storage the cell at temperature range of -10 ~ +45°C, low humidity, no corrosive gas atmosphere, No press on the cell; And more than 3 months need to put a charge according to the standard charge and discharge process